

MODEL : PK50

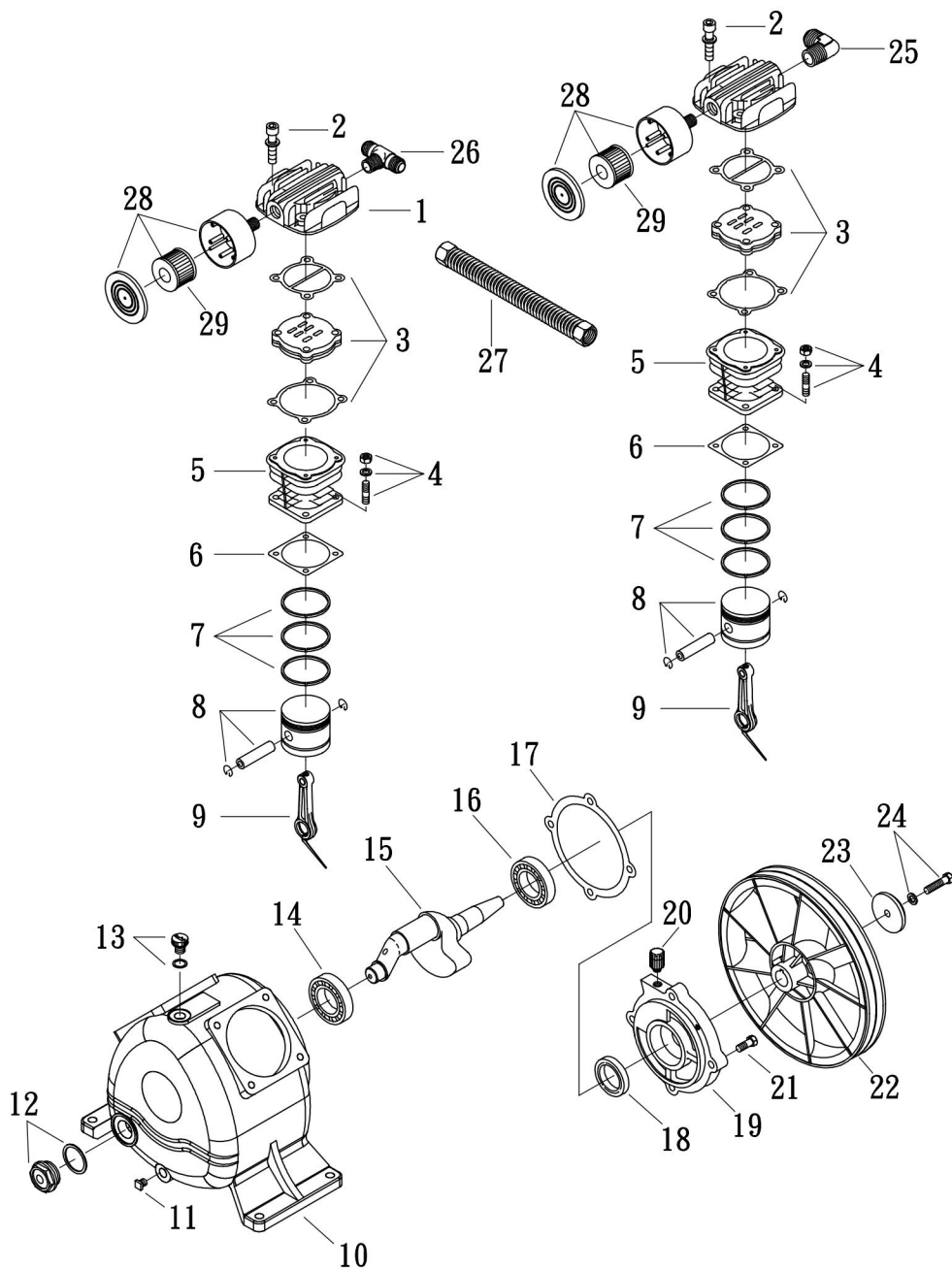

### SPARE PARTS LIST

NO : MP-1910

REF. NO.	DESCRIPTION	PART NO.	QTY.	REF. NO.	DESCRIPTION	PART NO.	QTY.
1	Cylinder head	3101052	2	16	Bearing	2N35-6205Z	1
2	Allen bolt set	3B01-M06*035V	8	17	Rear bearing seat gasket	2G06-008	1
3	In. & Ex. valve assembly	3B13-K5051C	2	18	Oil seal	2N50-TC24*47*07	1
4	Double head screw set	3B11-001-A	8	19	Rear bearing seat	3311034	1
5	Cylinder	3201036G	2	20	Breathing cover	2321008	1
6	Cylinder gasket	2G04-002	2	21	Hexagon bolt	2B00-SM08*020	4
7	Piston ring set	3B32-51N	2	22	Pulley	3PBF-105A124	1
8	Piston set	3B31-51N	2	23	Plate washer	2B30-08*35*35	1
9	Rod set	3B33-H1048	2	24	Hexagon bolt set	3B00-SM08*035AV	1
10	Crankcase	3301124	1	25	Exhaust elbow	2N06-04T04H	1
11	Oil draining plug	2N33-002	1	26	Exhaust three way pipe	2N09-04H04T04H1	1
12	Oil sight gauge set	2303012A	1	27	Exhaust tube set	3B2-04*225	1
13	Oil filling plug set	2319003A	1	28	Air filter set	2140019A	2
14	Bearing	2N35-6204	1	29	Filter element	2142013	2
15	Crankshaft & balancer	3304038	1				